



# Material-process-performance relationships for roll-to-roll coated PEM electrodes

PI: Michael Ulsh

Presenter: Scott Mauger

MN-019

This presentation does not contain any proprietary, confidential, or otherwise restricted information.

## Timeline and Budget

- Project start date: 10/1/2016
- FY16 DOE funding: \$ 350,000
- FY17 planned DOE funding: \$15,000
- Total DOE funds received to date: \$ 350,000

## Barriers

Barrier	Target
A. Lack of high-volume MEA processes	\$20/kW (2020) at 500,000 stacks/yr
H. Low levels of quality control	

## **Project**

Study material-process-performance relationships to understand the effects of ink formulation, coating physics, and drying dynamics on morphology, electrochemistry, proton conduction, and mass transport for roll-to-roll (R2R) coated PEMFC/EC cell materials. Provide a proof-of-scalability pathway for industry, lab and academic partners, e.g. ElectroCat, FC-PAD, HydroGen, L'Innovator

## **FY 2017**

Establish baselines for spray-coated and R2R-coated catalyst-coated diffusion media, and R2R-cast membranes

# Relevance – Project Addresses MYRD&D Plan Milestones

## Task 1: Membrane Electrode Assemblies

- |     |  |
|-----|--|
| 1.2 | Develop processes for direct coating of electrodes on membranes or gas diffusion media. (4Q, 2017)                                   |
| 1.3 | Develop continuous MEA manufacturing processes that increase throughput and efficiency and decrease complexity and waste. (4Q, 2017) |

## Task 5: Quality Control and Modeling and Simulation

- |     |   |
|-----|---|
| 5.5 | Develop correlations between manufacturing parameters and manufacturing variability, and performance and durability of MEAs. (4Q, 2018) |
|-----|---|

- Roll-to-roll (R2R) processes represent the lowest cost/highest throughput method for production of FC materials
- R2R coating techniques require different formulation of catalyst and ionomer dispersions and have different intrinsic physics than lab-scale processes which may affect morphology, uniformity, performance, and durability
- Many companies/universities/labs do not have or have access to the infrastructure to understand how the conditions and processes of R2R will impact their materials
- Results directly relevant to fuel cell producers – small and large – and academic/national laboratory researchers

# Collaborations

Institution	Role
<u>National Renewable Energy Laboratory</u> <ul style="list-style-type: none"><li>• Mike Ulsh, Scott Mauger, K.C. Neyerlin</li><li>• Jonathan Stickel</li></ul>	<ul style="list-style-type: none"><li>• Prime; Electrode production, coating, rheology, MEA performance testing, advanced diagnostics</li><li>• Unfunded, rheology advisor. High quality collaboration that enables rheological measurement of catalyst and membrane inks; not in DOE Hydrogen and Fuel Cells Program</li></ul>
<u>Oak Ridge National Laboratory</u> <ul style="list-style-type: none"><li>• Karren More</li></ul>	<ul style="list-style-type: none"><li>• Unfunded; Electron microscopy of electrode materials; Crucial to understanding morphology of electrode materials; In DOE Hydrogen and Fuel Cells Program</li></ul>
<u>AMO Roll-to-Roll Consortium</u> <ul style="list-style-type: none"><li>• David Wood</li></ul>	<ul style="list-style-type: none"><li>• Collaborating on roll-to-roll coating</li></ul>

# Approach

- Understand foundational relationships between ink rheology, interparticle interactions, coating and drying physics, and film microstructure in R2R-coated electrodes and membranes
- Leverage advanced diagnostic techniques and electron microscopy developed through FC-PAD to correlate microstructure to electrochemical performance, proton transport, and mass transport.
- Utilize this fundamental understanding to develop innovative ink formulations and coating processes to optimize membrane, catalyst, and MEA properties and performance

Date	Milestone/Deliverable (as of 4/10/2017)	Complete
12/2016	Fabricate and characterize baseline ultrasonic-sprayed electrodes for process study.	100 %
6/2017	Fabricate and characterize baseline slot-die and micro-gravure roll coated electrodes on R2R coating station.	70 %
9/2017	Fabricate and characterize baseline cast membranes on R2R coating station.	0 %

# Approach (Background) – Electrode Production

## Lab Scale – Ultrasonic Spray

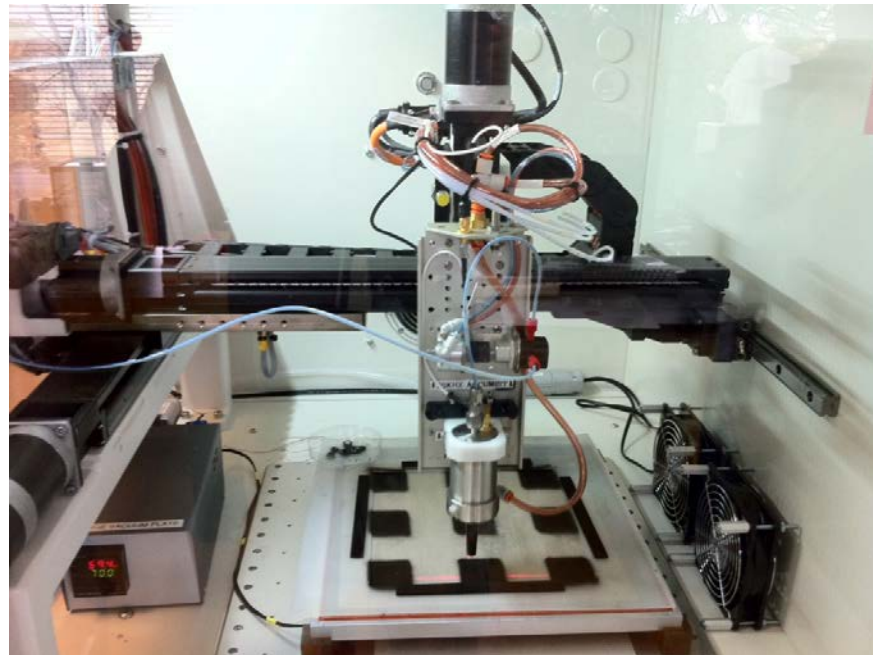

Used to demonstrate new materials and for fundamental studies

### Conditions

- Dilute ink (~0.6 wt% solids)
- Ultrasonic mixing
- Sequential build up of layers
- Heated substrate
- Vacuum substrate

## Large Scale – Roll-to-Roll (R2R)



Needed to demonstrate industrial relevance and scalability of materials and MEA/cell designs

### Conditions

- Concentrated ink (~4.5 wt% solids)
- Shear mixing
- Single layer
- Room temp. substrate
- Convective drying

# Approach (Background) – Electrode Types

## Catalyst-Coated Membrane (CCM)

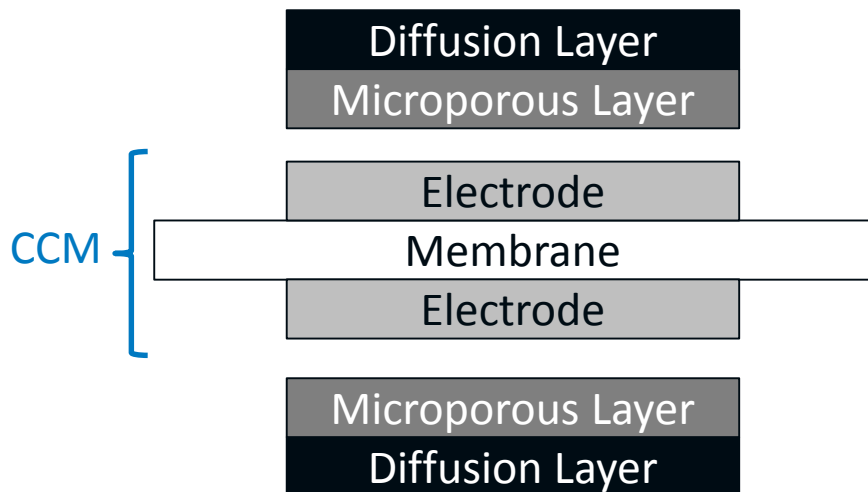

- Electrode applied to membrane
- Extensive knowledge and large body of research at NREL and in literature
- Difficult for manufacturing due to swelling of membrane

## Catalyst-Coated Diffusion Media (CCDM aka GDE)

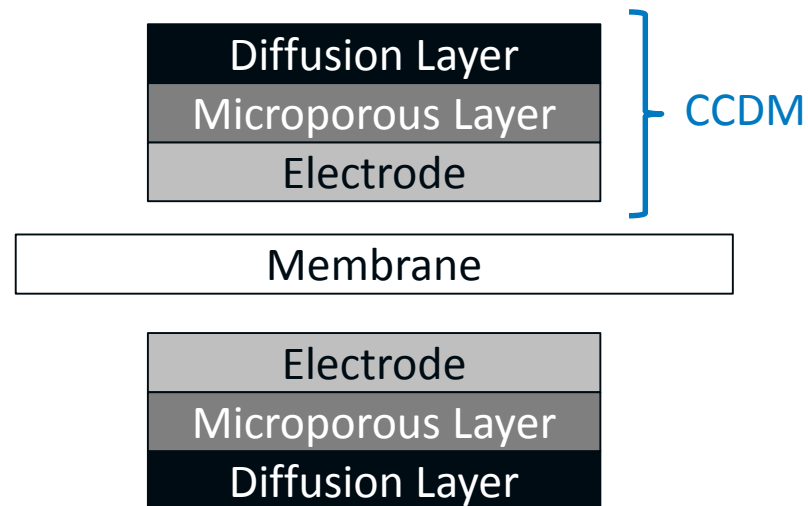

- Electrode applied to microporous layer, over coated with thin layer of ionomer, then hot pressed to membrane
- Less experience at NREL and fewer studies in literature
- Easier for manufacturing and preferred by industry



# Accomplishments and Progress:

## Achieved Comparable Performance between Spray-Coated CCM and CCDM

Pt/HSC, 50 wt% Pt  
100 %RH  
150 kPa

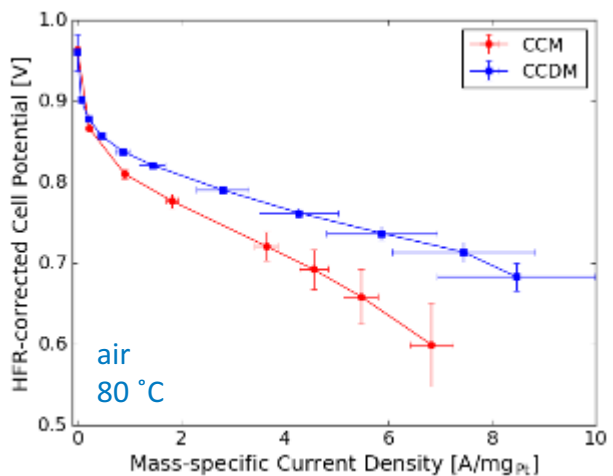
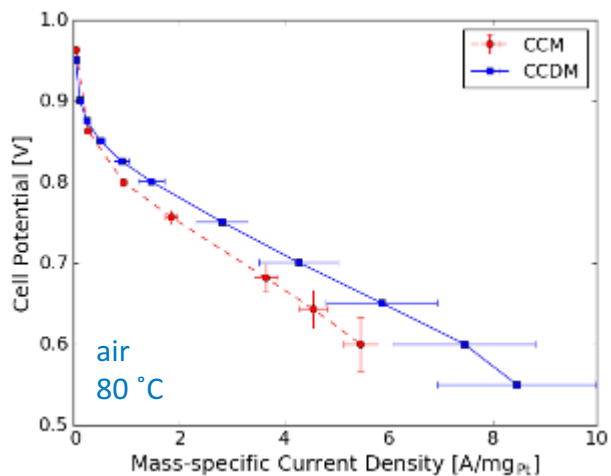
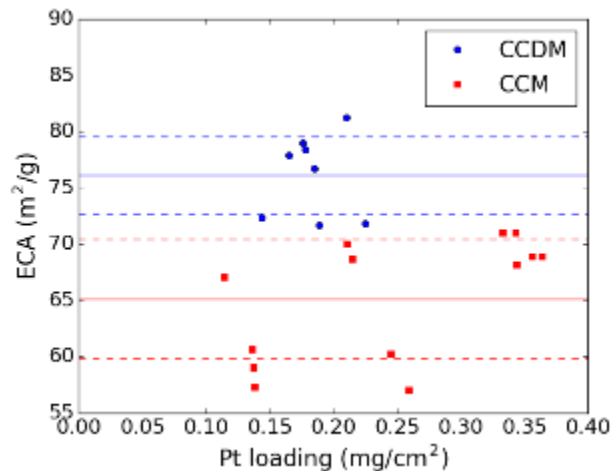
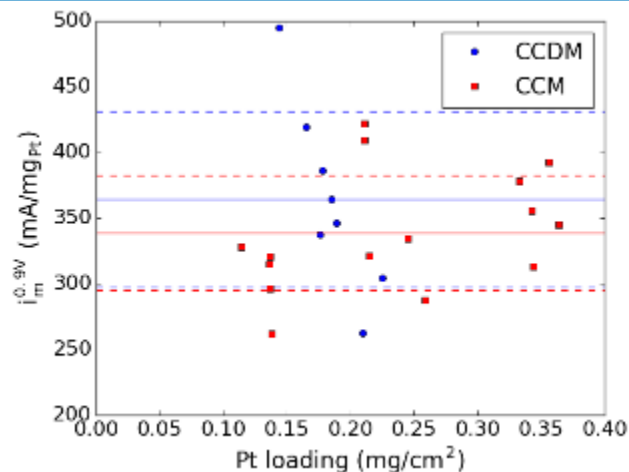

- This project leverages NREL's expertise, data, and experience in MEA testing from FC-PAD and our MEA Integration core competency
- Also utilizes advanced diagnostics techniques such as impedance spectroscopy and limiting current measurements

# Accomplishments and Progress: Determined Catalyst Ink Viscosity Dependent on Carbon Type and Pt

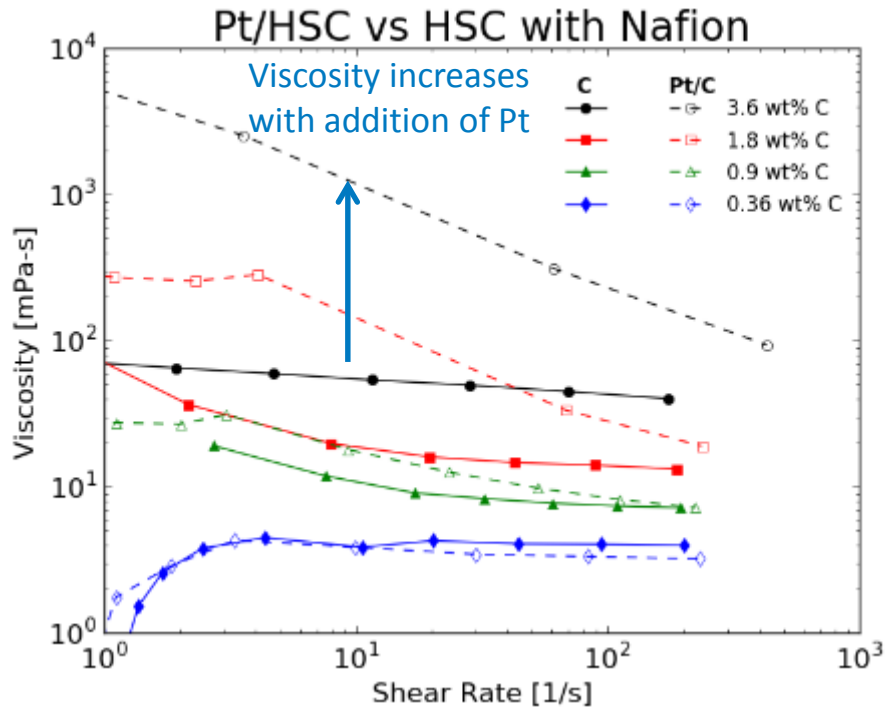
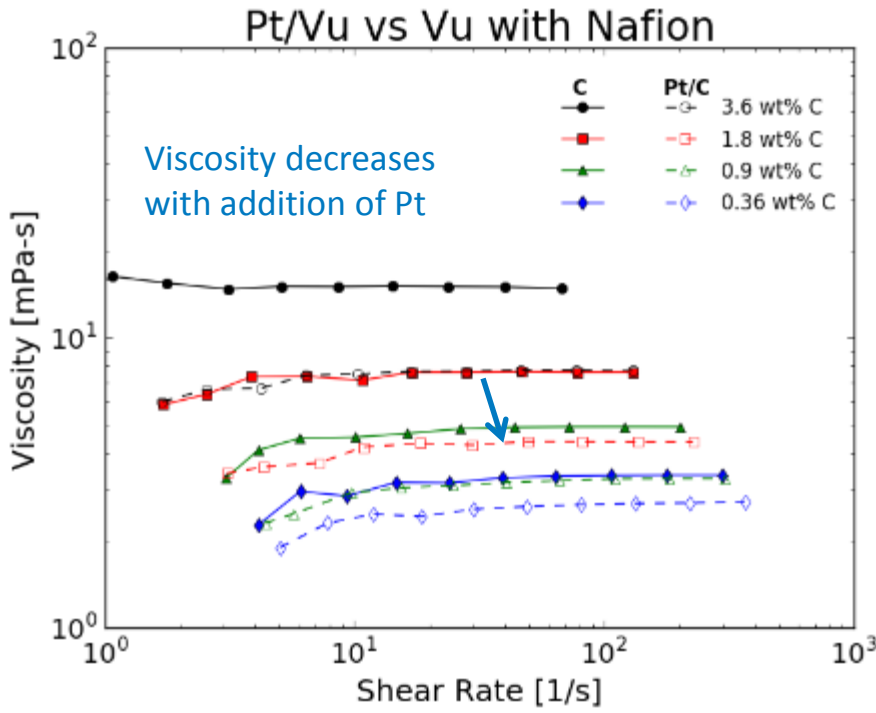

Material	BET Surface Area [m <sup>2</sup> /g <sub>C</sub> ]	Pore Volume [cm <sup>3</sup> /g <sub>C</sub> ]
Vulcan XC-72	237	0.62
Pt/Vulcan (TEC10V50E)	166	0.52
HSC (TKK E-type carbon)	802	1.33
Pt/HSC (TEC10E50E)	554	0.89

- Vulcan – Newtonian      HSC – Shear thinning
- HSC more viscous than Vulcan due to larger pore volume
- Addition of Pt changes viscosity in opposite directions for Vulcan (decrease) and HSC (increase)
- Hypothesis: different ionomer interactions between carbon types

# Accomplishments and Progress: Gravure Coating Configuration

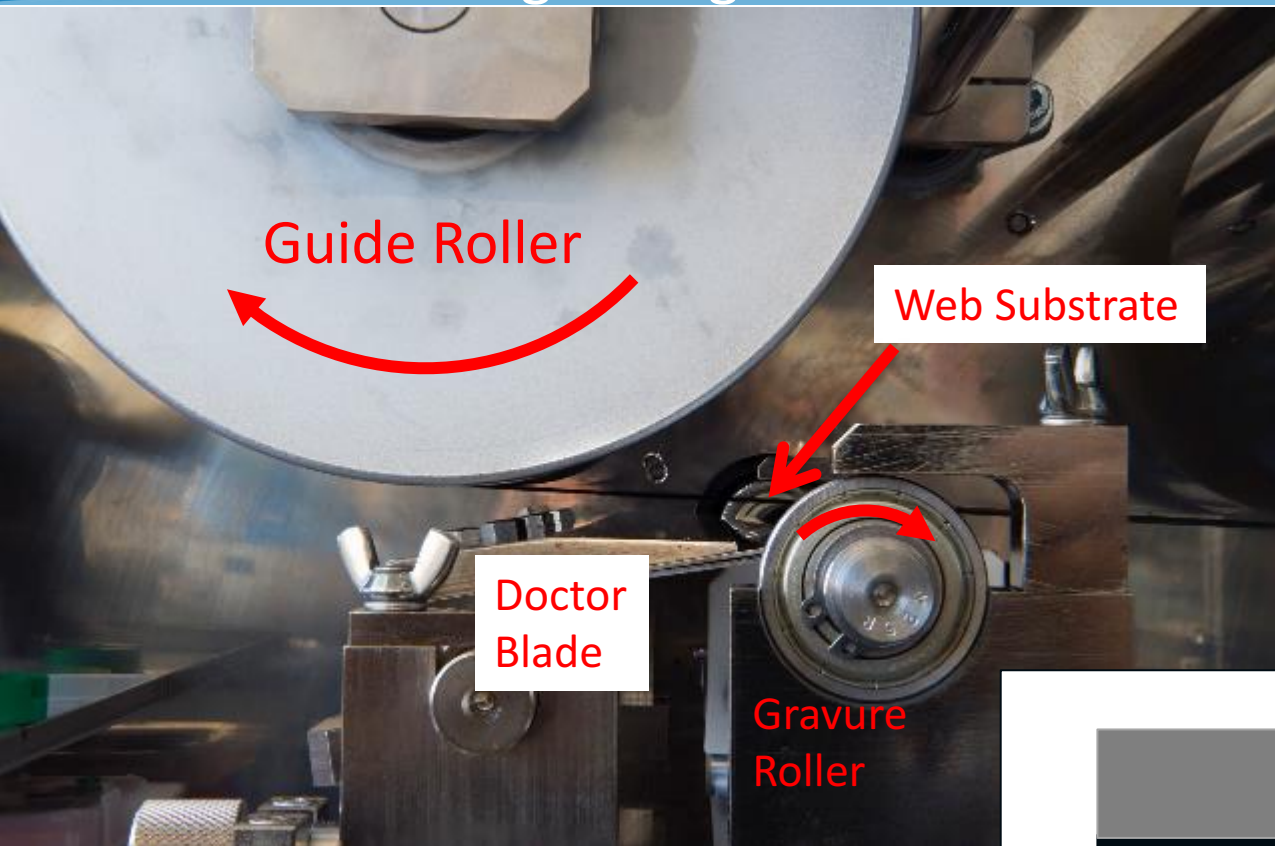

Gravure Roller

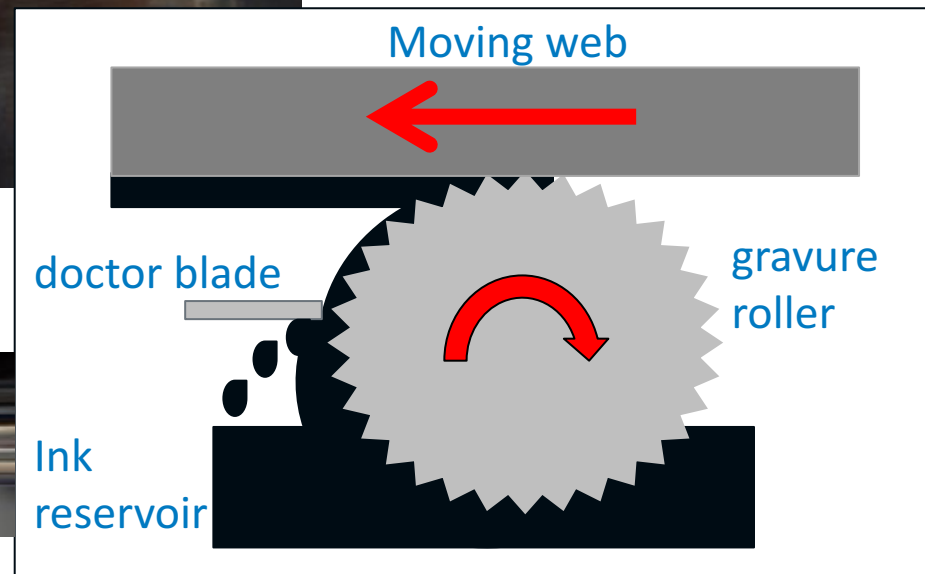
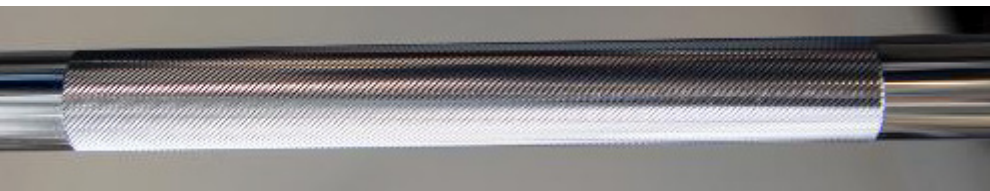

# Accomplishments and Progress: Loading and Coating Quality Dependent on Roller Speed

Pt/HSC, 50 wt% Pt  
Nafion 1000 EW  
3.2 wt% PtC  
0.9 I:C  
SGL 29BC

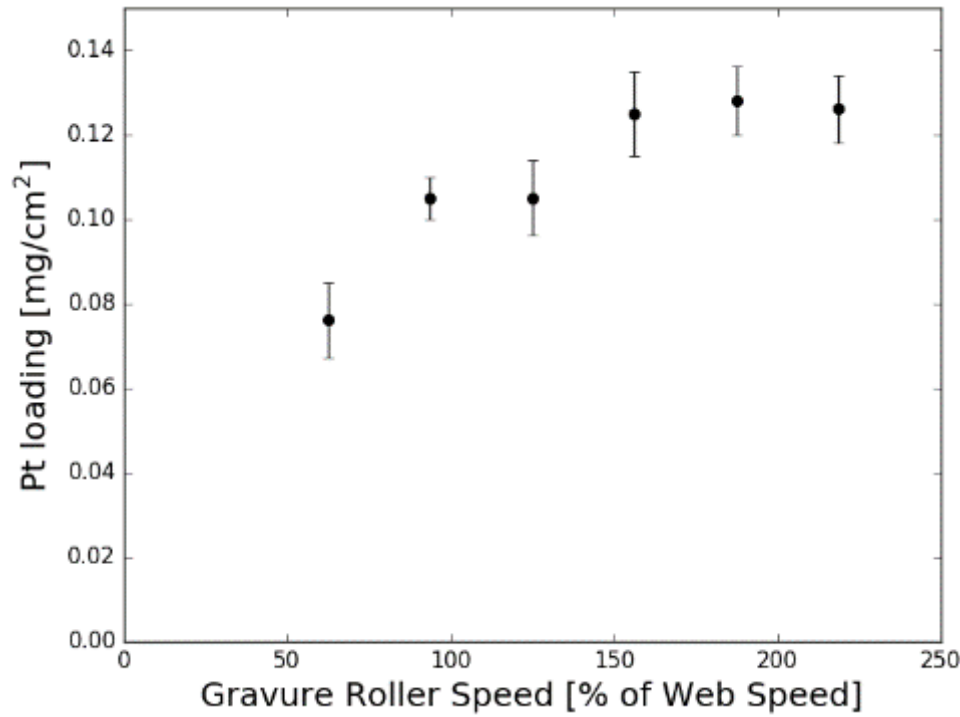

- 7 m coated on SGL 29BC roll (15 cm x 50 m)
- About 1 m long section coated at each condition
- Loading measured by XRF, average of 5 points in 50 cm<sup>2</sup> area from 1m section
- Low gravure roller speed (relative to web speed) results in coating defects
- Increasing loading (coat weight) with roller speed follows expected trend

31 %

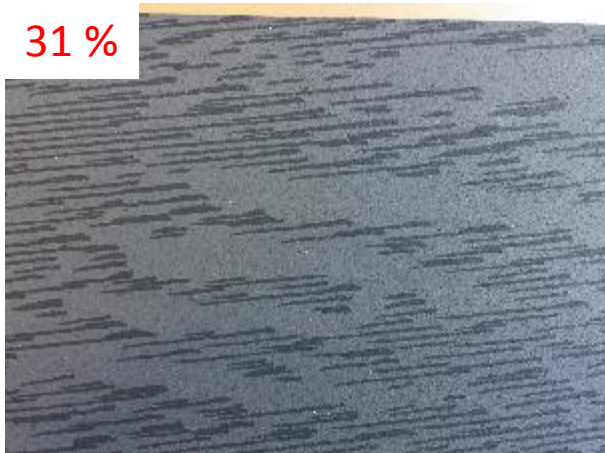

63 %



94 – 219 %

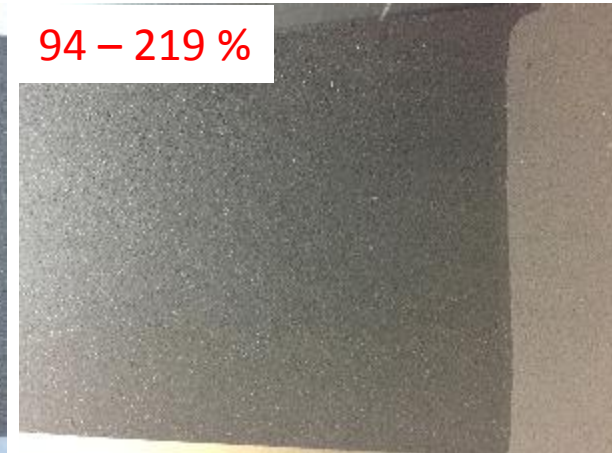

# Accomplishments and Progress: Coating Quality Dependent on Roller Speed and Pattern

Gravure Roller

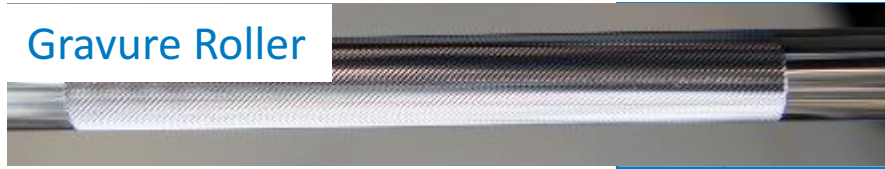

Gravure Roller Pattern

三角形の溝がラセン状に彫られており、高粘度の  
糊り、転移性の悪い粘着材等のコーティングに適しま  
す。



線数 (L/inch)	深度 ( $\mu$ )	セル容積 ( $\text{cm}^3/\text{m}^2$ )
36	275	138
38	255	131
45	305	149
50	195	100
55	165	81
60	220	105
65	130	65
70	150	73
75	160	82
80	130	67
85	150	73
90	95	49
95	90	46

		Gravure Roller Speed [%]		
		100	150	200
Gravure Roller Wet Film Thickness [ $\mu\text{m}$ ]	12-20			
	30-45			
	50-80			

- Thinner films must be coated with higher roller speeds for defect-free coatings
- Relationship between roller pattern, viscosity, and surface tension seems to determine coating quality

Pt/HSC, 50 wt% Pt  
Nafion 1000 EW  
3.2 wt% PtC  
1.2 I:C  
SGL 29BC

# Accomplishments and Progress: Achieved High Quality Coating with Gravure Method

## Uncoated MPL

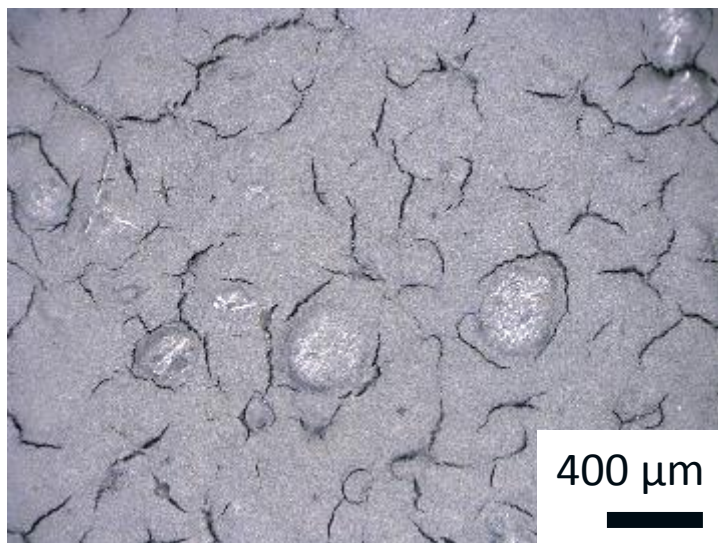

## Spray Coated

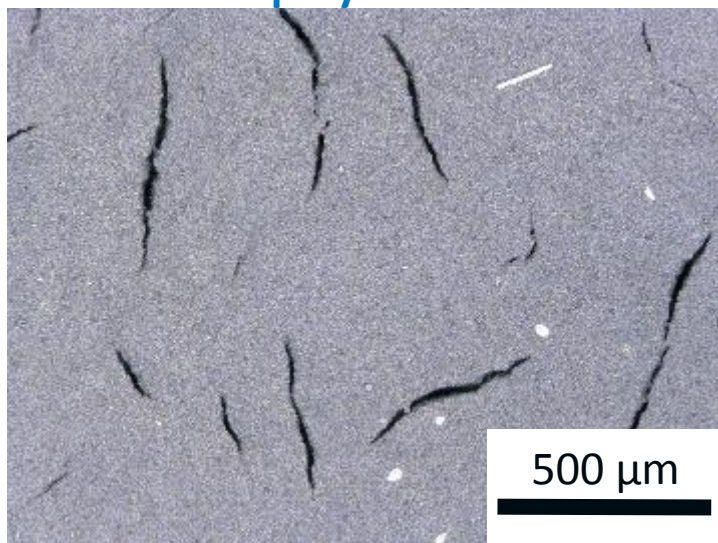

## R2R Gravure Coated

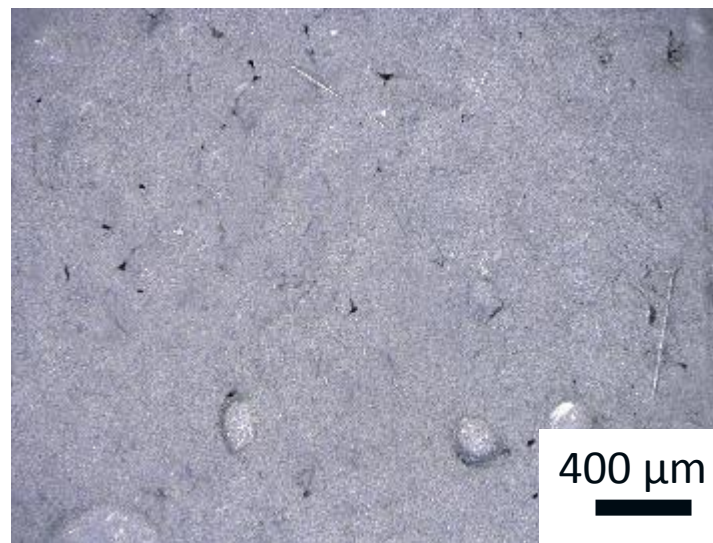

Pt/HSC, 50 wt% Pt  
Nafion 1000 EW  
3.2 wt% PtC  
0.9 I:C  
SGL 29BC

- PtHSC/Nafion (0.9 I:C) on SGL 29BC roll (15 cm x 50 m)
- Viscous R2R ink mostly covers cracks in MPL, **no microscale coating defects**
- Less viscous spray-coated ink does not fill cracks

# Accomplishments and Progress:

## TEM shows higher porosity in gravure coated catalyst layers

Spray Coated

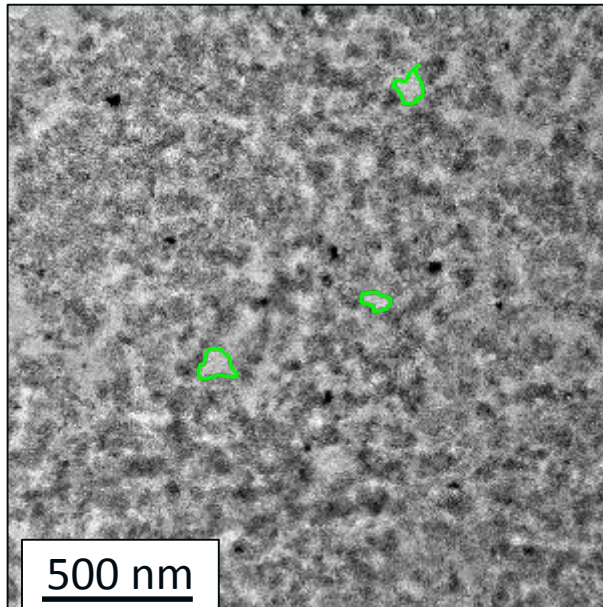

Gravure Coated

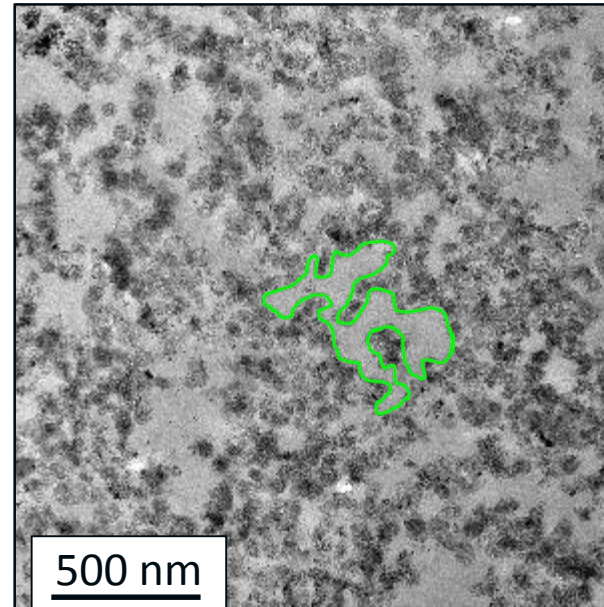

- Gravure-coated layers have much higher porosity than spray-coated catalyst layers
- Gravure-coated catalyst layers less dense than spray-coated
- Larger high-density agglomerates in spray-coated catalyst layers than gravure-coated catalyst layers

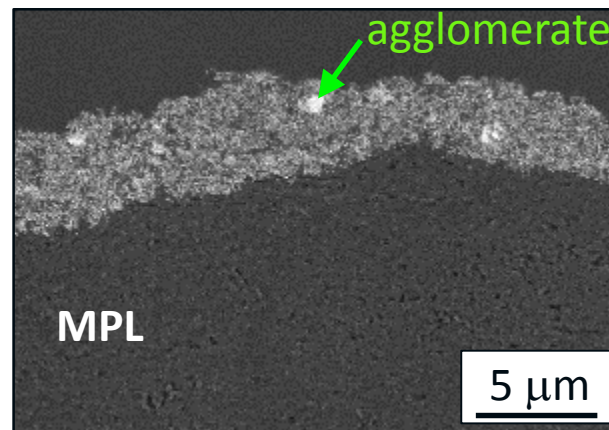
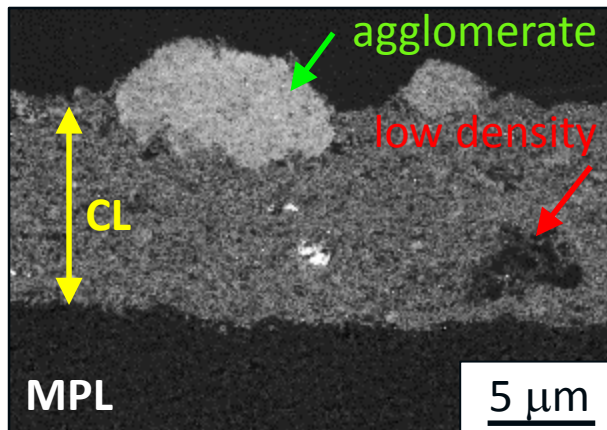

# Accomplishments and Progress: RIF Mapping Shows High Uniformity of Gravure Coating

Pt/HSC, 50 wt% Pt  
Nafion 1000 EW  
3.2 wt% PtC  
0.9 I:C  
SGL 29BC

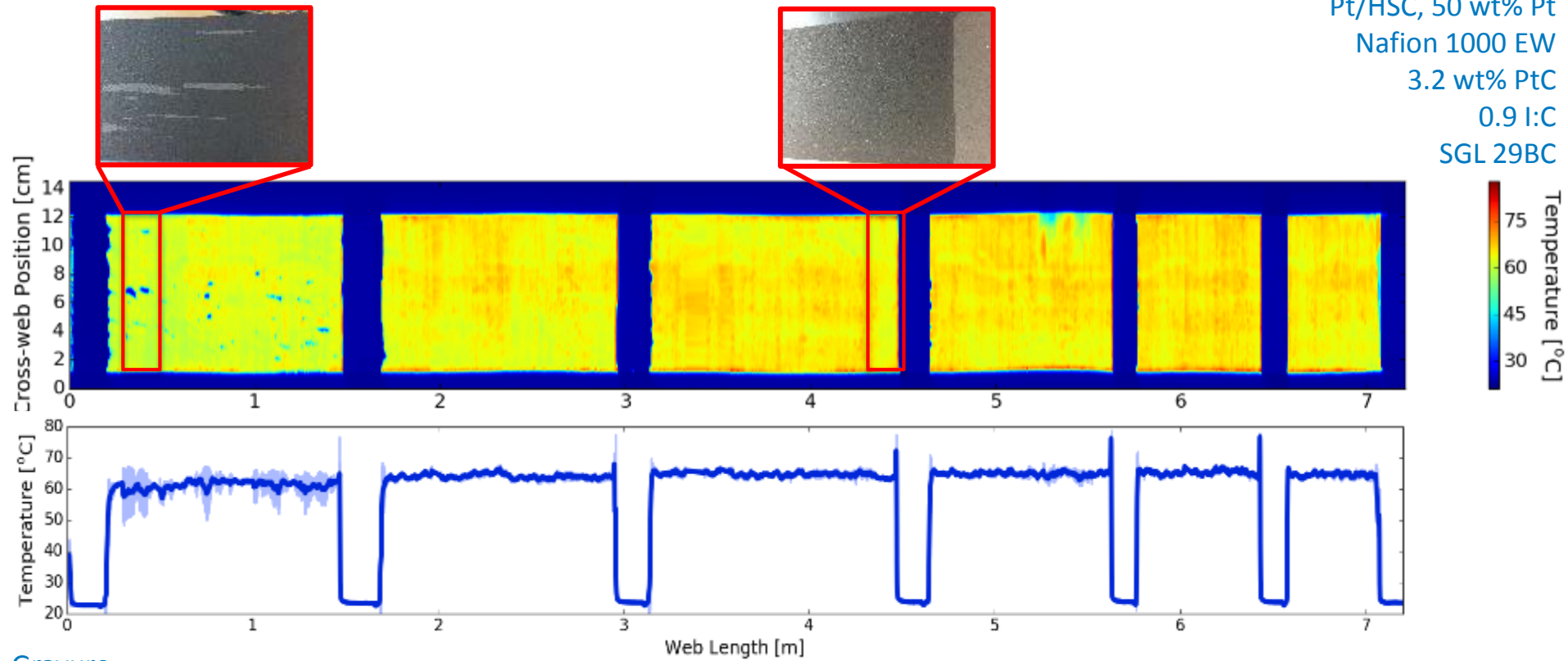

	0-1 m	1-2 m	2-3 m	3-4 m	4-5 m	5-6 m	6-7 m
Gravure Roller Speed	63 %	94 %	125 %	156 %	188 %	219 %	
$T_{avg}$	61.1 °C	63.9 °C	64.6 °C	64.8 °C	65.2 °C	64.5 °C	
$T_{StDev}$	3.9 °C	1.3 °C	1.3 °C	1.4 °C	1.1 °C	1.3 °C	
Loading [ $mg_{Pt}/cm^2$ ]	0.08	0.11	0.11	0.13	0.13	0.13	

**Loading correlates with temperature**

Ulsh, 2017 AMR. MN001, 6/8/17 1:45 pm  
Zenyuk, *J. Power Sources* 2016, 332, 372-382.



# Accomplishments and Progress

## Demonstrated Higher Loadings with Slot Die Coating

### Tensioned Web Over Slot Die Coating

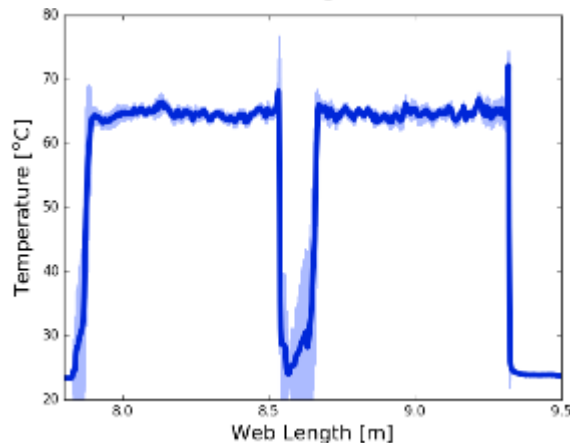
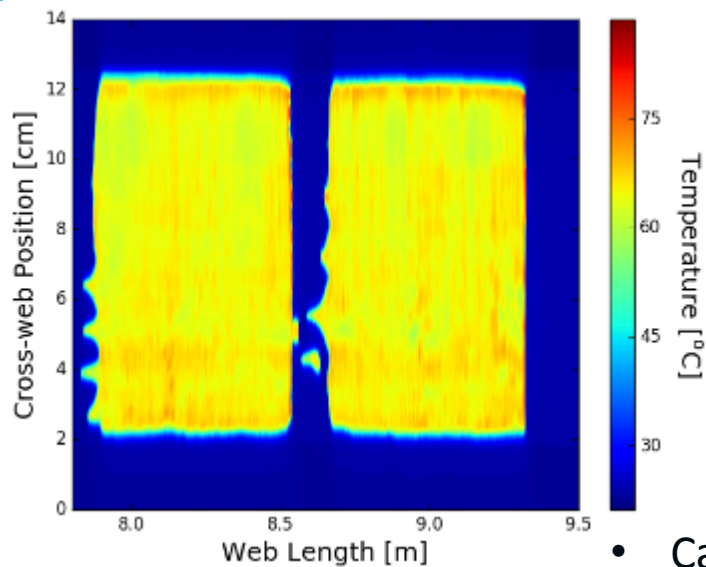
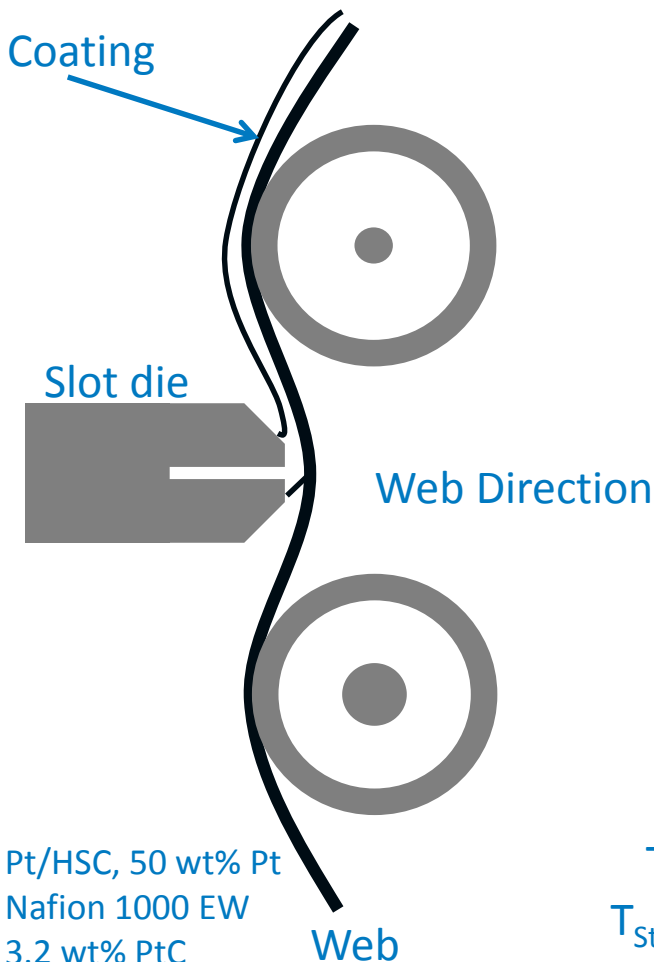

- Can coat thicker films than with gravure
- Coating less uniform than gravure, thus far
- Variation in temperature does not correlate well with XRF
- Process improvements and more data analysis needed

Pt/HSC, 50 wt% Pt  
Nafion 1000 EW  
3.2 wt% PtC  
0.9 I:C  
SGL 29BC

Web

$T_{avg}$	64.5 °C	64.6 °C
$T_{StDev}$	1.2 °C	1.3 °C
Avg Loading	0.215 mg <sub>Pt</sub> /cm <sup>2</sup>	0.196 mg <sub>Pt</sub> /cm <sup>2</sup>
Std Dev.	0.075 mg <sub>Pt</sub> /cm <sup>2</sup>	0.066 mg <sub>Pt</sub> /cm <sup>2</sup>

# Accomplishments and Progress:

Achieved Comparable High-Current Density Performance between Gravure R2R and Spray

## Pt/HSC CCDM Performance

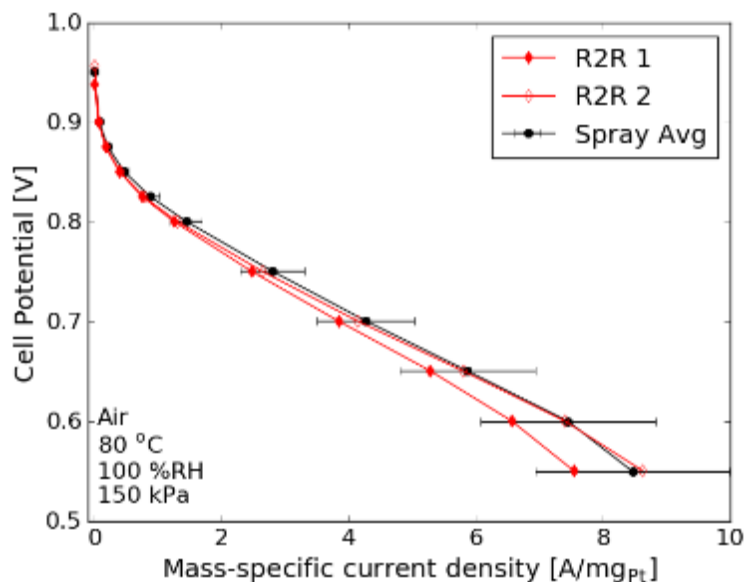

Coating Method	ECA [m <sup>2</sup> /g]	$i_m^{0.9V}$ [mA/mg]	$i_s^{0.9V}$ [μA/cm <sup>2</sup> ]
Spray Coated Avg	76 ± 4	364 ± 66	460 ± 64
R2R MEA 1	74.7	255	341
R2R MEA 2	70.1	268	383

- Gravure-coated MEAs have inferior activity to spray-coated MEAs
- Comparable performance at high current density
- Similar proton resistance for spray and R2R
- Exploring diffusion limited current measurements to understand mass transport

## Advanced Diagnostics

### Electrochemical Impedance Spectroscopy

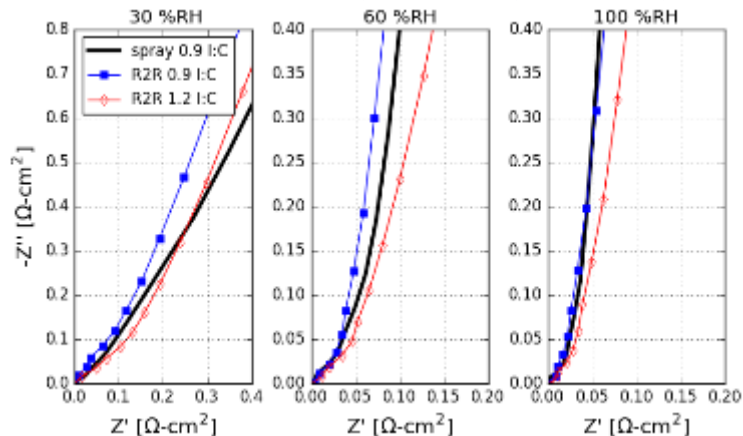

### Diffusion Limited Current

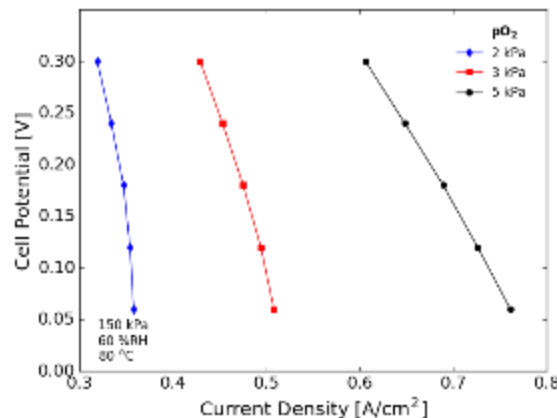

K. C. Neyerlin, et al., *ECS Meeting Abstracts*, MA2016-02 (38), 2492 (2016).

A. Weber, AMR 2017 FC137: FC-PAD: Electrode Layers and Optimization

# Accomplishments and Progress: Responses to Previous Year Reviewers' Comments

- This project was not reviewed last year.

# Remaining Challenges and Barriers

- Improve R2R-coated electrode performance to match spray-coated electrode performance
  - Barriers: Understanding of R2R-coated electrode morphology, penetration of catalyst and/or ionomer into microporous layer, impact of ink formulation, polymer-catalyst interactions, and coating physics on electrode morphology and performance
- Improve uniformity of slot coated electrodes
  - Barriers: understand sources of variation
- Coat membranes with performance equivalent to commercially available products
  - Barriers: determination of optimal coating parameters, understand influence of environmental conditions

## FY2017

- Improvement in R2R-coated electrode performance through improved understanding of materials-property-performance relationships
  - Influence of coating physics, rheology, interparticle forces on electrode morphology
  - Effects of electrode morphology on electrochemical properties, proton resistance, and oxygen transport
  - Utilize TEM (K. More, ORNL) to characterize morphology, thickness-dependent composition
- Low Pt loaded electrodes
- Coat electrodes onto transfer liner
- Coating and qualification of R2R-coated membranes (9/2017)
  - Influence of coating and drying physics on membrane properties
- Rheology of catalyst layer inks
  - Understand difference between Vulcan and high surface carbon catalyst supports
  - Examine ionomer to carbon ratio

## FY2018

- Optimize electrode performance, more detailed parametric studies, durability

## Current Funding

- Small Business Voucher with Alteryg
  - High-speed spray coating of PEMFC electrodes
  - Leverages knowledge of concentrated inks
  - Increased throughput by 100x over NREL's standard spray coating procedure

## Potential Future Funding for R2R research

- SBV
- AMO R2R FOA
- AMO R2R Consortium

# Summary

**Objective:** Study material-process-performance relationships for R2R PEMFC/EC cell materials to understand relationships between process science and material properties and performance

**Relevance:** Addressing MYRD&D milestones with lowest cost/highest throughput methods for production of FC materials.

**Approach:** Understand impacts of substrate, ink formulation, coating and drying physics on film morphology, electrochemistry, proton conduction and mass transport

## **Accomplishments:**

- Translated lab-scale electrode fabrication to R2R fabrication using two coating techniques
- Coated electrodes with 72% the mass activity of spray coated electrodes and equivalent high-current density performance.
- Gravure-coated catalyst layers have larger pores than spray-coated catalyst layers
- Leveraged FC-PAD-developed capabilities to determine correlations between process science, electrode morphology, and performance
- Discovered differences in rheological properties of supported catalyst inks suggesting differences in polymer-particle and/or particle-particle interactions

# Technical Backup Slides



# Approach: NREL's R2R Coating Station

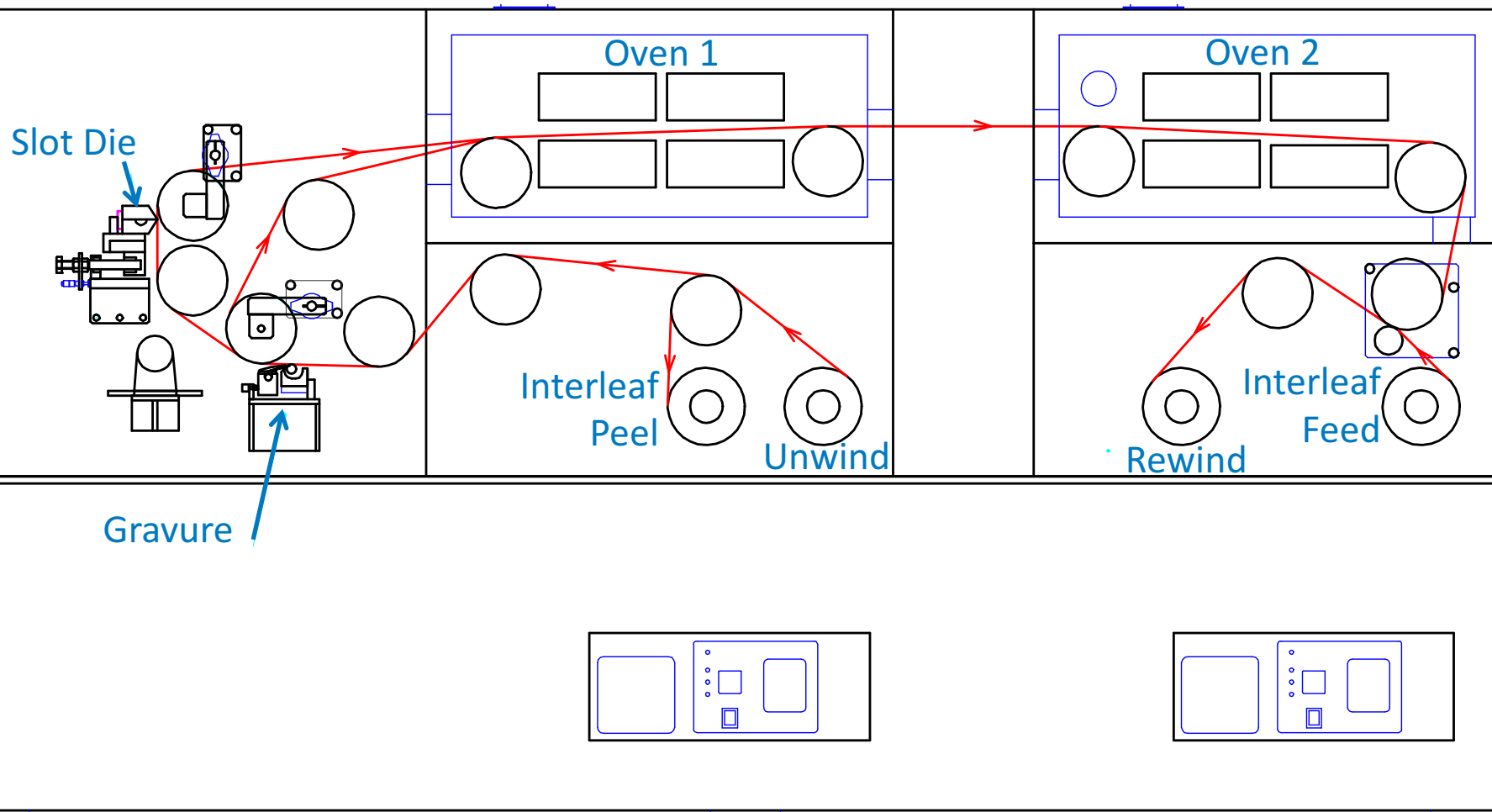

Web speed: 0.1 – 10 m/min

Oven temperature: up to 220 °C

Web width: up to 300 mm

# Approach: Reactive Impinging Flow (RIF) of R2R Coated Materials

Zenyuk, J. Power Sources 2016, 332, 372-382.

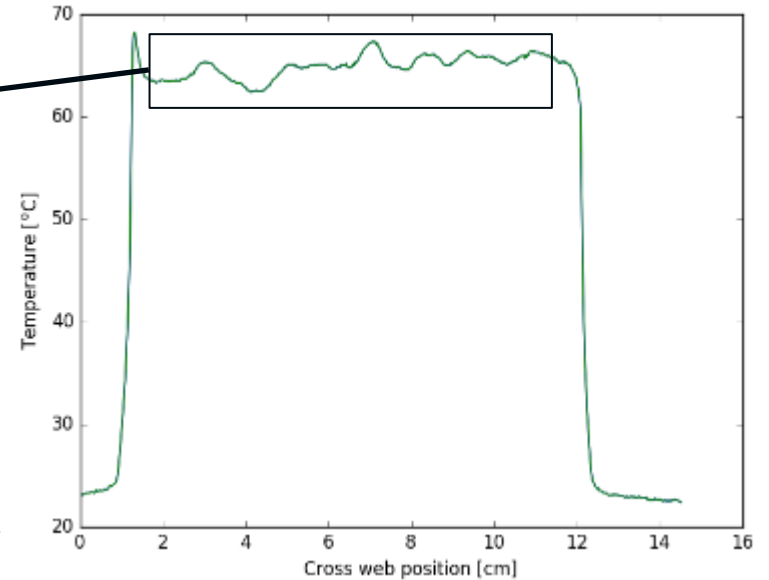
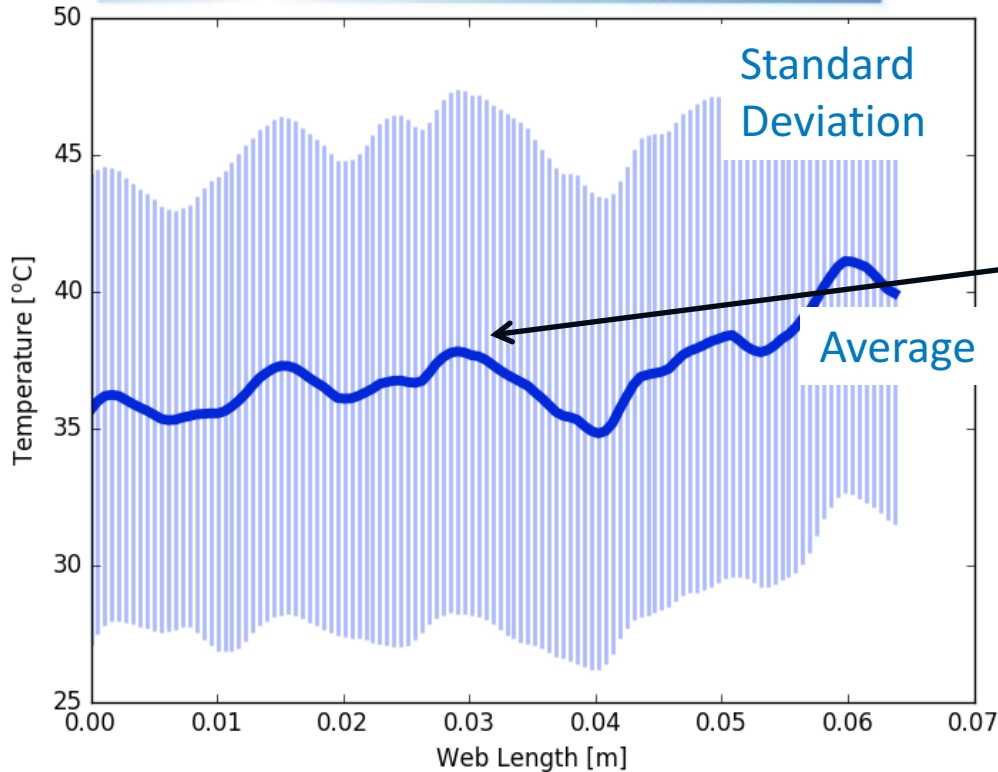
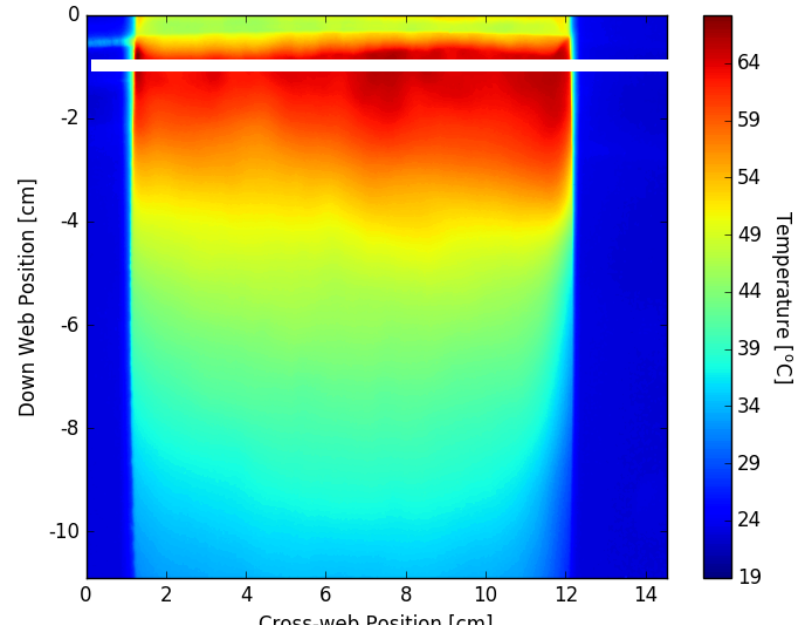
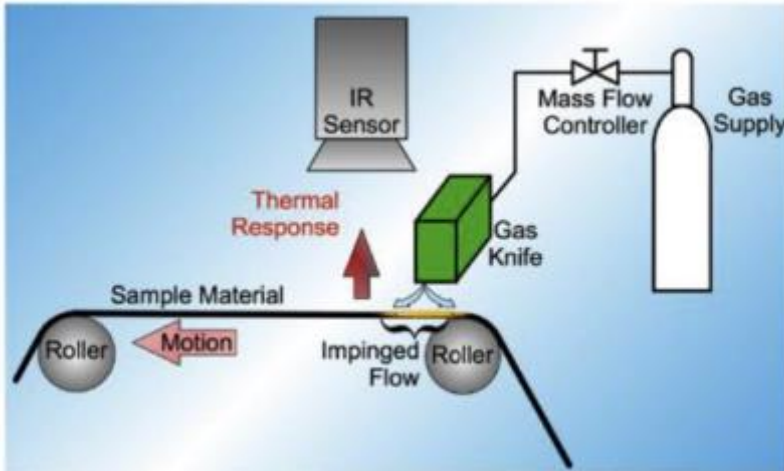

# Accomplishments and Progress: Measured Rheology of Individual Components

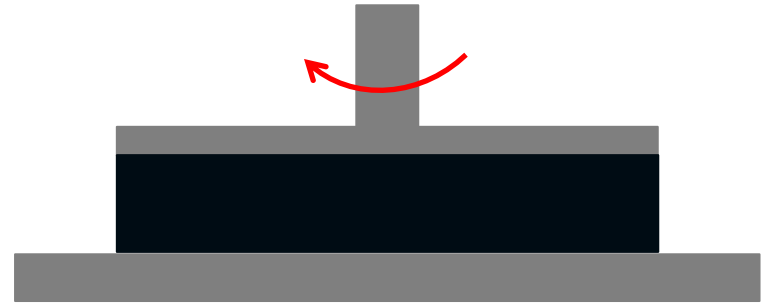
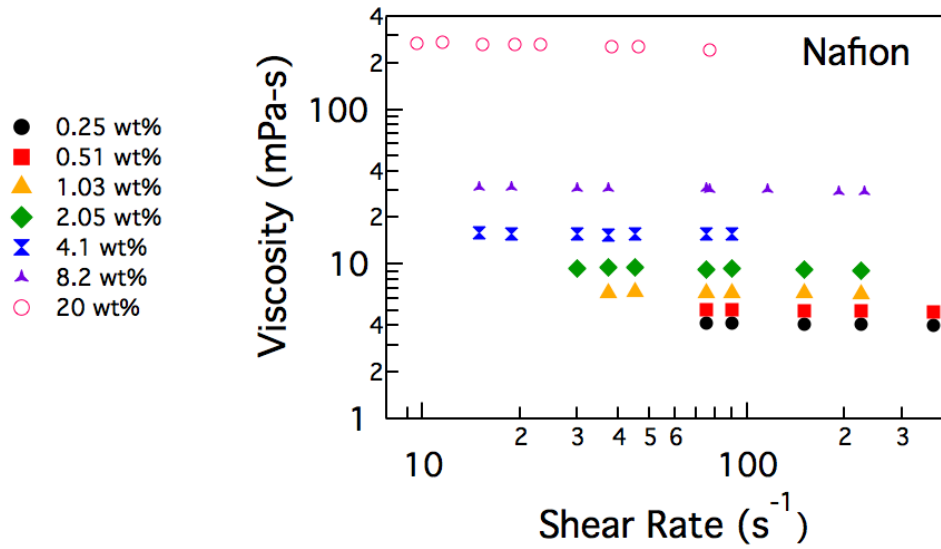

- Nafion: Newtonian, even at 20 wt%!
- Carbon blacks are shear thinning
- Higher viscosity of Ketjen due to ~4x higher void volume

